

# CNFL08875

## DEEP CYCLE CARBON NANO FLOODED

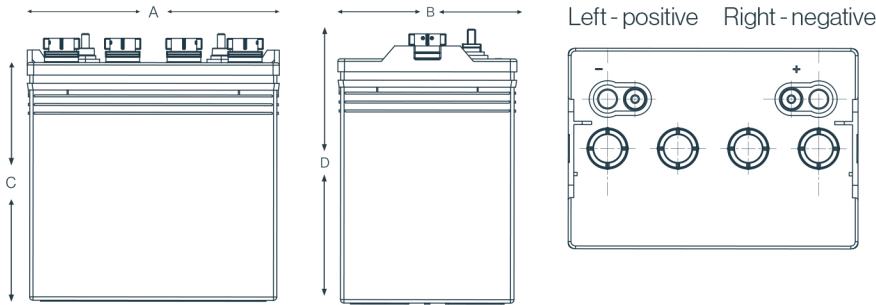

### Features

- Ultra energy efficient due to low resistance
- Increased cycle life due to Carbon Nano Tube Technology
- Suitable for opportunity charging
- Cost savings due to increased efficiency
- Up to 2 x faster recharge
- Allows for opportunity charging to give you those extra running times when required
- Suitable for extreme temperature variants

### Electrical Specifications

<b>C5 Capacity</b>	145Ah
<b>C20 Capacity</b>	170Ah
<b>Voltage</b>	8V
<b>80% DOD Voltage Cutoff</b>	7.5V
<b>Self Discharge</b>	Less than 3% per month (20°C/68°F)
<b>Charge Temperature</b>	Min: -10°C (14°F) / Max: 50°C (122°F)
<b>Discharge Temperature**</b>	Min: -40°C (-40°F) / Max: 50°C (122°F)
<b>Storage</b>	Min: -20°C (-4°F) / Max: 60°C (140°F)

### Mechanical Specifications

<b>Industry Reference</b>	GC8	
<b>Length (A)</b>	10.2 in	260 mm
<b>Width (B)</b>	7.1 in	180 mm
<b>Height over lid (C)</b>	9.7 in	247 mm
<b>Height over stud (D)</b>	10.9 in	277 mm
<b>Weight</b>	63.9 lbs	29 kgs
<b>Terminal (Opt'l)</b>	UTL	
<b>Cell(s)</b>	4	
<b>Electrolyte</b>	Flooded	
<b>Terminal Torque Nm</b>	11-12Nm	

NOTE: There is a tolerance of +/-2%.

### Capacity vs Temperature

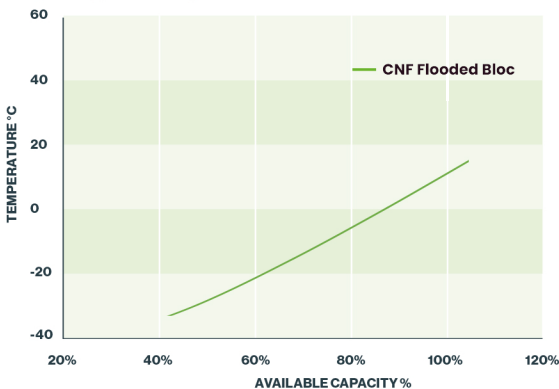

### IUI Charging

I<sub>1</sub> = min. 12% C<sub>5</sub> max. 40% C<sub>5</sub>  
 U = 2.45 V per cell  
 I<sub>2</sub> = 6% C<sub>5</sub> for max. 4 hours

### Applications

- Golf carts, including electric vehicles
- Access Work Platform (AWP)
- Cleaning Machines
- Maritime
- Wheelchairs
- Solar & Renewable Energy
- Traffic Systems
- Caravans / Motorhomes RV's
- Home Invertor

### UTL

### Positive & Negative

