

KBHR12550 12V 55Ah

The Kaise HR batteries were specially designed for applications that demand a very high energy output. With an optimized design of the grids and an excellent formula for pasting the plates, the HR series can deliver up to 40% more than the standard series.



Performance Characteristics

Nominal Voltage	12V	
Dimensions	Length (mm / inch)	229 / 9.02
	Width (mm / inch)	138 / 5.43
	Height (mm / inch)	203 / 7.99
	Total Height (mm / inch)	203 / 7.99
Approx Weight	Kg / lbs 17.3 / 38.1	
Design Life	10 years	
Terminal	M6	
Container Material	ABS	
Rated Capacity	232.3Watts / Cell	(15min, 1.60V / cell, 25°C / 77°F)
	55Ah	(20hr, 1.80V / cell, 25°C / 77°F)
Max. Discharge Current	825A (5s)	
Internal Resistance	Approx 5mΩ	
Operating Temp. Range	Discharge : -15 - 55°C (5 - 131°F)	
	Charge : 0 - 40°C (32 - 104°F)	
	Storage : -15 - 40°C (5 - 104°F)	
Nominal Operating Temp. Range	25 ± 3°C (77 ± 5°F)	
Cycle Use	Initial Charging Current less than 11.0A	
	Voltage: 14.4V-14.7V at 25°C (77°F)	
	Temp. Coefficient: -30mV/°C	
Standby Use	Initial Charging Current less than 11.0A	
	13.9V-13.8V at 25°C (77°F)	
	Temp. Coefficient: -20mV/°C	
Capacity affected by Temperature	40°C (104°F)	103%
	25°C (77°F)	100%
	0°C (32°F)	86%
Self Discharge	Fully charged Kaise High Rate Series batteries may be stored for up to 6 months at 25°C (77°F) and then a freshening charge is required. For higher temperatures the time interval will be shorter.	

Discharge Constant Current (Amperes) at 77°F (25°C)

Volts/cell	10min	15min	20min	30min	1h
1.80V	114.2	95.7	80.2	69.0	34.2
1.75V	126.4	103.4	85.8	62.8	35.4
1.70V	137.7	110.9	91.2	66.0	36.6
1.60V	155.6	123.8	100.0	70.8	38.9

Dimensions and Terminal (Unit: mm (inches))

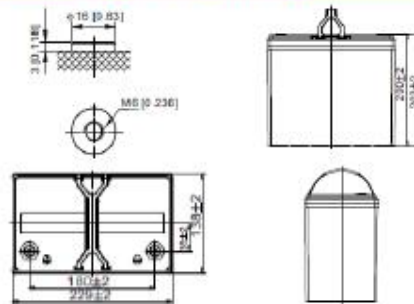

Applications

UPS
High power backup supply
Electric facilities
Power tools

Certifications

ISO 9001:2008 ISO 14001:2008



Discharge Current vs. Discharge Voltage

Final discharge voltage VCELL	1.8	1.75	1.7	1.6
Discharge current (A)	I ≤ 0.1CA	0.25CA ≥ I > 0.1CA	0.55CA ≥ I > 0.25CA	I > 0.55CA

Discharge Constant Power (Watts per cell) at 77°F (25°C)

Volts/cell	10min	15min	20min	30min	1h
1.80V	221.1	186.4	157.0	118.1	68.0
1.75V	242.4	199.6	166.5	122.7	70.8
1.70V	261.2	211.5	175.2	127.6	71.8
1.60V	289.8	232.3	189.0	134.8	75.2

(Note) The above characteristics data are average values obtained within three charge/discharge cycles not the minimum values.

KBHR 12550 12V 55Ah



Charging Characteristics (cycle use)

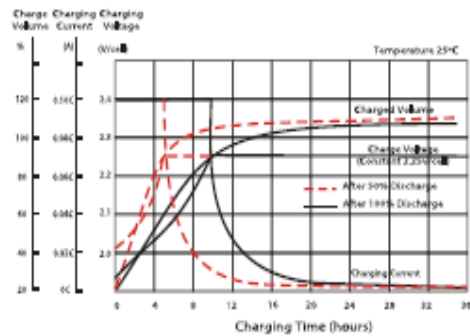

Temperature Effects in Relation to Battery Capacity

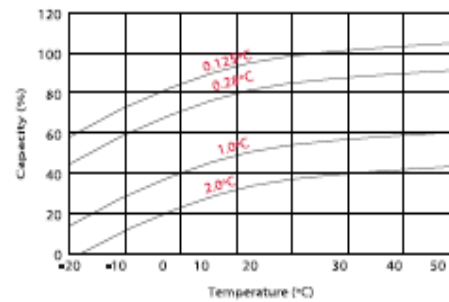

Self Discharge Characteristics

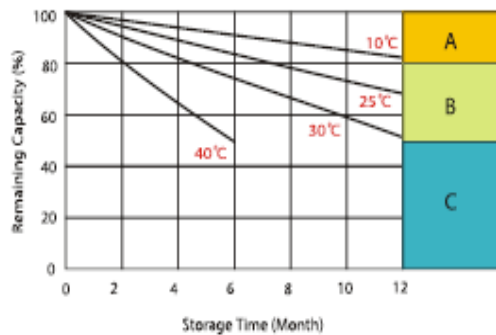

- A** No supplementary charge required
(carry out supplementary charge before use if 100% capacity is required)
- B** Supplementary charge required before use. Optional charging way a below:
 1. Charged for above 3 days at limited current 0.25 CA and constant voltage 2.25V / cell.
 2. Charged for above 20 hours limited current 0.25CA and constant voltage 2.45V / cell.
 3. Charged for 8-10 hours or limited current 0.05 CA.
- C** Supplementary charge when fail to recover the capacity.
The battery should never be left standing till this is reached.

Effect of Temperature on Long Term Float Life

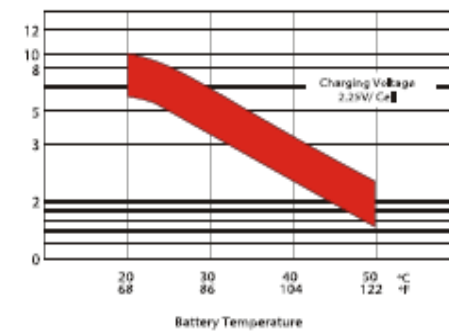

IMPORTANT NOTE: The specifications presented herein are subject to revision without notice.