

Batería de Litio 12.8 Voltios 54 Amperios Premium battery KBLI12540

[Reguero Baterias, S.L](#) - Glorieta de las Amazonas, 10 - Valdemoro - Madrid - 91-7973512

KBLI12540 12.8V 54Ah



Longer Cycle Life: Offers up to 20 times longer cycle life and five times longer float/calendar life than lead acid battery, helping to minimize replacement cost and reduce total cost of ownership.

Lighter Weight: About 40% of the weight of a comparable lead acid battery. A 'drop in' replacement for lead acid batteries.

Higher Power: Delivers twice power of lead acid battery, even high discharge rate, while maintaining high energy capacity.

Wider Storage Temperature Range: -20 °C - 60 °C

Superior Safety: Prismatic Lithium Iron Phosphate chemistry eliminates the risk of explosion or combustion due to high impact, overcharging or short circuit situation.

Physical Dimension-mm

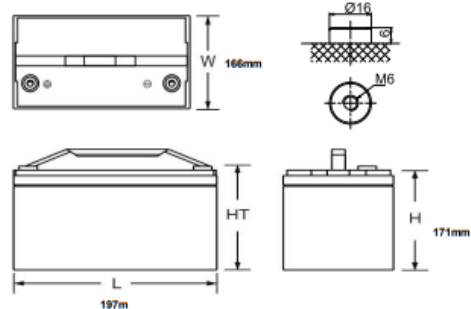

Electrical Performance

| | |
|------------------|---------------------|
| Nominal Voltage | 12.8 V |
| Nominal Capacity | 54 Ah |
| Capacity @ 10.8A | 300 min |
| Energy | 691.2 Wh |
| Resistance | ≤45 mΩ @ 50% SOC |
| Self Discharge | <3% / Month |
| Cells | 32700 Cell 3.2V 6Ah |

Charge Performance

| | |
|-----------------------------|-----------------------|
| Recommended Charge Current | 10.8 A |
| Maximum Charge Current | 54A |
| Recommended Charge Voltage | 14.6 V |
| Charge Cut-Off Voltage | <15.2 V (0.5 ~ 1.5 s) |
| Reconnect Voltage | >14.4 V |
| Balancing Voltage | <14 V |
| Maximum Batteries in Series | 4 |
| Parallels Support | |

Discharge Performance

| | |
|--------------------------------------|---------------------|
| Continuous Discharge Current | 27 A |
| Maximum continuous Discharge Current | 54 A |
| Peak Discharge Cut-Off Current | 115 A(5 ~15 ms) |
| Recommended Low Voltage Disconnect | 10 V |
| Discharge Cut-Off Voltage | >8.4V (50 ~ 150 ms) |
| Reconnect Voltage | >10 V |
| Short Circuit Protection | 200 ~ 600 μs |

Mechanical Performance

| | |
|-----------------------|---|
| Dimension (L x W x H) | 197 x 166 x 171 mm 7.75 x 6.53 x 6.73" |
| Approx. Weight | 6.5 kg |
| Terminal Type | M6 |
| Terminal Torque | 80 ~ 100 in-lbs (9 ~ 11 N-m) |
| Case Material | ABS |
| Enclosure Protection | IP65 |

Temperature Performance

| | |
|--------------------------|---------------------------|
| Discharge Temperature | -4 ~ 140 °F (-20 ~ 60 °C) |
| Charge Temperature | 32 ~ 113 °F (0 ~ 45 °C) |
| Storage Temperature | 23 ~ 95 °F (-5 ~ 35 °C) |
| High Temperature Cut-Off | 149 °F (65 °C) |
| Reconnect Temperature | 118 °F (48 °C) |

Compliance

| | |
|-------------------------|-----------------------------------|
| Certifications | CE UN38.3 UL1642 & IEC62133 |
| Shipping Classification | UN 3480, CLASS 9 |

KBLI12540 12.8V 54h



Performance Characteristics

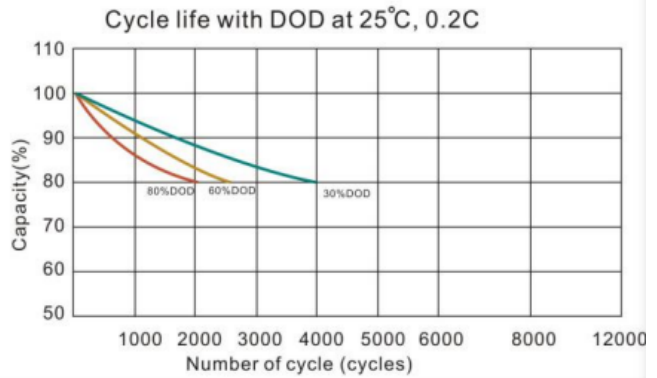
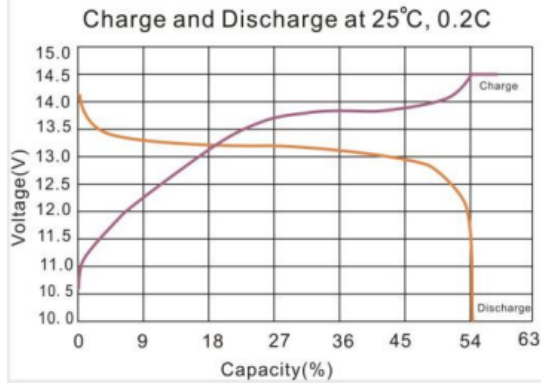
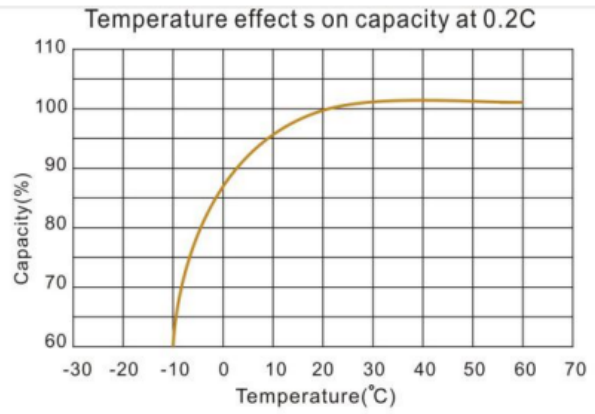
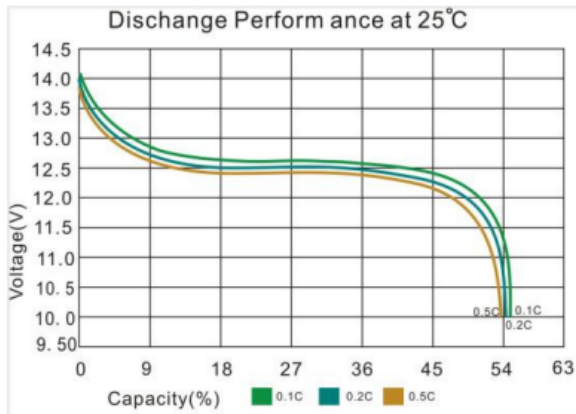

KBLI12540 12.8V 54h



FEATURES & BENEFITS



High cycle life

>2000 cycles @80% DoD for effectively lower total cost of ownership.



Longer service life

Low maintenance batteries with stable chemistry. Easily monitor state of charge (SoC) of smart models.



Built in circuit protection

Battery Management Systems (BMS) are incorporated against abuse.



Better storage

Up to 6 months thanks to its extremely low self discharge (LSD) rate and no risk of sulphation.



Quickly recharge

Save time and increase productivity with less down time thanks to superior charge/discharge efficiency.



Extreme heat tolerance

Suitable for use in a wider range of applications where ambient temperature is unusually high: up to +60°C.



Lightweight

Lithium batteries provide more Wh/Kg while also being up to 1/3 the weight of its SLA equivalent.

APPLICATIONS

Lithium Iron Phosphate can be used in most applications that use Lead Acid, GEL or AGM type batteries. Suitable applications include:

- Caravan
- Marine
- Wheelchairs and scooters
- Solar / wind energy storage
- Back-up power for small UPS
- Golf trolleys & buggies
- Electric bikes
- Tools

CAUTIONS

- Do NOT short circuit, crush or disassemble.
- Do NOT heat or incinerate.
- Do NOT immerse in any liquid.
- Store at 50% capacity. Recharge every 3 months. The storage area should be clean, cool, dry and ventilated.