

MVDZM12140F2 is specially designed for deep cycle discharge and grouping usage in electric vehicle application. By the special active material design in the plate, it makes battery have more than 350 cycles life time by 100% D.O.D. Specially, the consistency performance of grouping usage is much better than general series.

MVDZM12140F2

Battery Dimensions

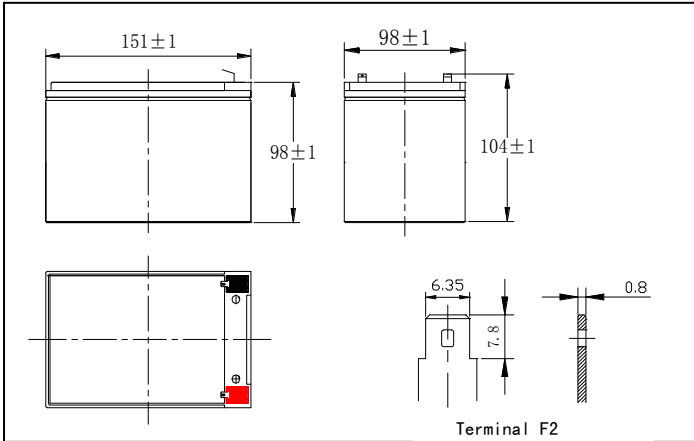

SPECIFICATION

Nominal voltage	12V	
Rated capacity (5 hour rate)	14Ah	
Number of cell	6	
Approx. Weight (Kg)	4.5	
Dimensions	Total Height	4.10inches(104mm)
	Height	3.86inches(98mm)
	Length	5.94inches(151mm)
	Width	3.86inches(98mm)

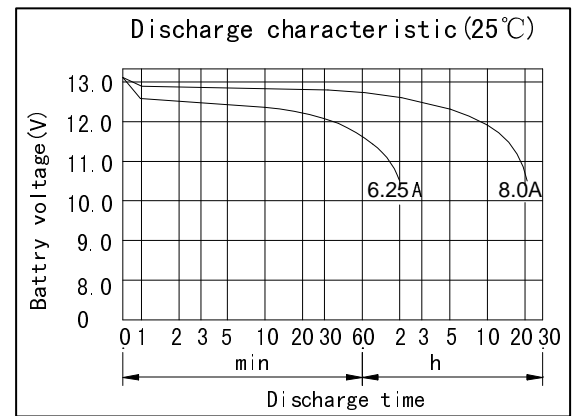

Characteristics

Capacity 77° F(25°C)	20 hour rate (0.8A、10.5V)	16Ah
	2 hour rate (6.25A,10.5V)	12.5Ah
Internal Resistance	Full charged Battery 77° F(25°C) : 13m Ω	
Operating Temperature Range	Discharge: -20~60°C	
	Charge: -10~60°C	
	Storage: -20~60°C	
Self-Discharge 3% of capacity declined per month at 20°C(average)		
Max. discharge current 77° F(25°C) : 160 A (5S)		
Charge (Constant Voltage)	Float: 13.6~13.8 V/77° F(25°C)	
	Cycle: 14.7 ~14.9 V/77° F(25°C) Max. Current: 2.5A	

