

# fullwat®

professional *solutions*

NHE2606F22FTB • Ready to use



**NHE2606F22FTB • Ready to use**

**1. Model: NHE2606F22FTB**

**2. Ratings**

Nominal voltage	8.4V
Nominal	260mAh
Minimum	250mAh / 0.2C
Standard charge rate	26mA × 16h
Rapid charge rate	260mA × 72min (-ΔV= 5mV)
Standard discharge rate	26mA (0.2C)
Maximum discharge rate	260mA (1.0C)
Value of dT/dt (for reference only)	1 to 2 °C/min
Operating temperature range	Humidity: +65% ± 20%
Standard charge	0 to +40°C
Rapid charge	+10 to +40°C
Discharge	-20 to +50°C
Storage temperature range	Humidity: +65% ± 20%
Within 1 year	-20 to +35°C
Within 6 months	-20 to +45°C
Within 1 month	-20 to +50°C
Within 1 week	-20 to +50°C

**Notes:**

- (1) All rapid charge methods should be discussed with our engineer.
- (2) We stipulate to charge less than 60% fully power for delivery, if the charge is more than 60%, the battery has a certain latent risk. For the charge requirement is over 60% which caused quality problem, we do not undertake any responsibility.
- (3) Our battery guarantee time: 6 months, according to requirements of our sales conditions.
- (4) During storage period the batch battery is requested by the 60% electric charge, the battery storage surpasses 3 months, we suggest charge 60% every 3 months.
- (5) APPLICATION: The applicable range: This specification is available only for the testing within one month since receipt of batteries. It's not a standard for stored goods.

**3. Measurement & dimensions (cell) see the drawing:**

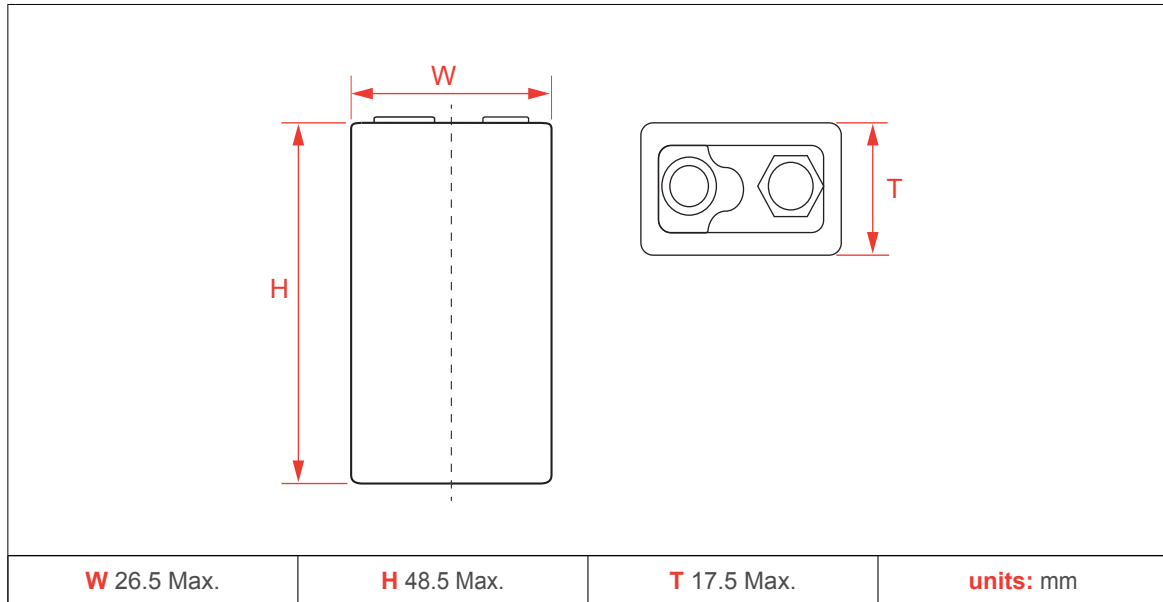

**4. Performance Testing**

**4.1. Test conditions**

**4.1.1. The battery to be tested is the product within one month after being received by customer.**

**4.1.2. Ambient conditions:**

Temperature      +20°C±5°C  
Humidity            +65%±20%

**4.2. Testing Tools**

**4.2.1. Voltage meter:**

0.5 level or higher as required in IEC51/IEC485. Internal impedance exceeds 10KΩ/V.

**4.2.2. Current meter:**

0.5 level or higher as required in IEC51/IEC485. Internal impedance should be less than 0.01Ω/V (including wires).

**4.2.3. Micrometer caliper:**

With precision of 0.02mm.

**4.2.4. Internal impedance meter:**

Alternating current of 1000Hz, connector measuring equipment with sinewave of 4.

**4.2.5. Impedance loaded meter:**

Value of impedance is with ±5% error allowed (including external wires).

**4.2.6. Incubators:**

Accuracy ±2°C

**NHE2606F22FTB • Ready to use**

**4.3. Test methods and benchmarks**

Item	Test Method	Benchmark
1 Appearance	Eyeballing	Batteries shall be free from any stains; scratches or deformations, which may reduce the commercial value when visually inspected.
2 Size	Caliper measurement.	The size shall comply with the specified size as the attached drawing.
3 Insulate impedance	Measured with a Megger overpack and battery electrode between the degree of insulation.	Outer sleeve shall exceed 10MΩ.
4 Weight	Using disk-scale measurement.	Approximate 52.0g.
5 Charge Voltage	Following a period of discharge at 0.2CmA down to a terminal voltage of 7.0V, standard charge, the cell or battery shall be checked at 5 minutes before finish charging.	The voltage shall be less than 11.2V.
6 Open circuit voltage: (O.C.V.)	Following a standard charge period, the open circuit voltage of the cell or battery shall be checked within 1 hour.	The O.C.V. shall exceed 8.75V.
7 Closed circuit voltage: (C.C.V.)	Following a standard charge period, the closed circuit voltage of the cell or battery shall be checked with a 0.86Ω per cell load within 1 hour.	The C.C.V. shall exceed 8.40V.
8 Internal impedance	Following a standard charge period, the internal impedance of the cell or battery shall be checked at 1000Hz within 1 hour.	The internal impedance shall not be more than 500mΩ.
9 Capacity	Following a standard charge period, the cell shall be stored for a period of 1 hour. The capacity shall be equal or more than minimum capacity when discharged at 0.2CmA down to a terminal voltage of 7.0V The capacity returned might not initially attain the specified value following the first charge–discharge cycle. In this event, the test may be repeated a further two or three times to attain the minimum capacity.	The capacity is greater than or equal to the minimum capacity. (Qualified if one of 3 cycles could meet the standard)
10 High Drain Discharge	To discharge by 1.0C to 7.0V within 1 hour after standard charge.	The Capacity is higher than or equal to 54 min.
11 Over-charge	Following a period of discharge at 0.2CmA down to a terminal voltage of 7.0V, standard charge and then charge for 48hrs at 0.1CmA. The capacity of the cell or battery shall not be less than the rated capacity when discharged at 0.2CmA.	It shall not be externally deformed and no leakage of electrolyte in liquid form shall be observed.
12 Over-discharge	Following a period of discharge at 0.2CmA down to a terminal voltage of 1.0V, combine the cells with a 0.86Ω per cell load. After stored for a period of 24 hours, standard charged and then discharge at 0.2CmA.	The cell or battery shall not be externally deformed and no leakage of electrolyte in liquid form shall be observed, and the subsequent capacity shall not be less than 80% of rated capacity.
13 Self discharge	Following a period of discharge at 0.2CmA down to a terminal voltage of 7.0V, standard charge and then the cell or battery shall be stored for 180 days below 20°C.	The subsequent capacity shall not be less than 85% of rated capacity when discharged at 0.2CmA.
	Following a period of discharge at 0.2CmA down to a terminal voltage of 7.0V, standard charge and then the cell or battery shall be stored for 360 days below 20°C.	The subsequent capacity shall not be less than 75% of rated capacity when discharged at 0.2CmA.

**NHE2606F22FTB • Ready to use**

Item	Test Method	Benchmark
14 Cycle Life	Based on clause 7.4.1.1, IEC61951-2 2003.	The charge-discharge cycles shall exceed 1000 times.
15 Humidity	Standard charge and store for 14 days under the following storage conditions: 33°C±3°C, Relative humidity of 80%±5%. (Salting is permitted).	No leakage of electrolyte in liquid form shall be observed.
16 Vibration	Store the cell or battery more than 24 hours after standard charge, following vibration tests over an amplitude of 4mm at a frequency of 16.7Hz (1000 cycles per minute) and repeated through any axes during 60mins.	The subsequent fluctuation of open circuit voltage and internal impedance shall be less than 0.14V and 35mΩ respectively, and the cell or battery shall not be externally deformed and no leakage of electrolyte in liquid form shall be observed.
17 Free falling: (Drop)	Store the cell or battery more than 24 hours after standard charge, following a drop test from 1000mm on to a hard-wood board in a vertical axis 2 times on each of 2 mutually perpendicular axes.	The subsequent fluctuation of open circuit voltage and internal impedance shall be less than 0.14V and 35mΩ respectively, and the cell or battery shall not be externally deformed and no leakage of electrolyte in liquid form shall be observed.
18 Short-circuit testing	Store the cell for 1 hour after standard charged, and to make positive and negative electrode short-circuit with a wire with the section 0.75mm <sup>2</sup> min and shortest length, the short-circuit time is 1 hour.	It shall not explode during or at the end of a 1 hour short-circuit test. However, leakage of electrolyte, external deformation or outer sleeve cracking is permitted.
19 Safety Valve Performance (Over discharging)	The battery to 0.1C discharge to 0V, then raise the current 1.0C discharge 60min.	The safety valve must start normally; battery without breakage. Leakage, distortion and outer package breakage are allowed.
20 Safety Valve Performance (Over charging)	Charged with 1CmA for 2.5 hours	No explosion, but leakage, distortion and out package breakage are allowed.
21 To discharge at low temperature	Stored for 24 hours at 0°C±2°C, and discharged at 0.2CmA at 0°C±2°C	Discharge duration shall exceed 3 hour and 30 min.

## 5. Transportation and storage

### 5.1. Transportation

In the transportation process the battery should maintain at clean, dry, and the well ventilated environment, and prevents the fierce vibration, the impact or the extrusion, prevents to be exposed to the sun and rain. Battery could be transported by automobile, train, steamboat, airplane and other transportation vehicle.

### 5.2. Storage

**5.2.1 Battery must be stored at -20°C ~ +35°C**, (It is best at +15°C ~ + 25°C) and put in the clean, dry and ventilated place with relative humidity 85% max.. It must be kept away from corrodent substance, fire hazard and heat resource.

#### 5.2.1 Storage placement way

The packed battery in a carton stack less than 5 layers, to guarantee that between the cell box has the good air circulation condition, please maintain between the carton above 5~10 cm distance, which prevents the safety incident caused by a pile of agglomeration to heat.

## 7. Warning and Security

To prevent the impact of equipment failure caused by the battery, and to make sure the security of circuit and battery set, please consider below things when design and produce the production equipment. Please put it into your instruction.

### **Danger!**

Against the following matters will result in battery leakage, heat, explosion, fire and serious personal injury!

- (1) Prohibited to throw the FULLWAT battery into fire or heat!
- (2) Prohibited to collide or throw FULLWAT battery!
- (3) Don't weld the lead on the FULLWAT battery directly.
- (4) Don't put the FULLWAT battery on a place which is more than 1.5 meter in case of dropping. Don't drop it at the height of more than 1.5 meter.
- (5) Don't connect the positive pole and electrode pole directly of FULLWAT battery, such as leading wire. If the tab terminal of poles doesn't set insulation covering, please don't transport or store. Please don't touch the metal necklace, key or any other conductive material. Please use special carton when transport or store.
- (6) Must use the charger appointed by FULLWAT to charge FULLWAT batteries, and follow the instructors of FULLWAT.
- (7) Prohibited to disassemble FULLWAT batteries. It will cause external or internal short circuit, and the exposed parts will have chemical reaction then result in very dangerous heat, explosion, fire or splash of electrolyte.

### **Warning!**

- (1) Don't contact batteries with water, sea water or other oxidation reagents, which will cause rustiness and heat. If batteries get rusty, explosive decompression valve won't work and will lead to explosion.
- (2) Don't over-charge FULLWAT batteries, that is, don't continually charge batteries despite the designed charging time. If the batteries are not fully charged within the designed charging time, please stop to charge. The delay of charging time will lead to leakage, heat and explosion.
- (3) FULLWAT NI-MH battery includes the colorless strong alkaline liquid (i.e. electrolyte), if the skin or clothes touch FULLWAT NI-MH battery liquid, please use the boron acid water or the vinegar acid water to clean, after that, with clear water thoroughly flushes. Because the battery's electrolyte can corrode the skin.
- (4) It is forbidden for more than 20pcs batteries in series. Because it will result in leakage, getting shock or giving off heat.
- (5) Don't disassemble the battery, as it will result in short-circuit, leakage, giving off heat, catching fire and explosion.
- (6) Don't use the batteries when they are leakage, any color deterioration, distortion or other changes are found. Otherwise it will get hot, catching fire or explosion may happen.
- (7) Please keep the batteries and other electronic products related to battery away from baby, children, to avoid accident of swallowing of battery. If there is any accident, please go to see the doctor.
- (8) To use new battery when the working time of the battery is far short from the initial working time, as the cycle life of this battery is finished.

## 8 Others

- FULLWAT reserve right to revise the specification without notification.
- Anything not mentioned in this specification, customer and FULLWAT should discuss to get a solution.
- FULLWAT does not undertake any responsibility for the accidents caused by actions not matching with specifications.