

MODEL **SAGM 12 105**
 VOLTAGE **12V**
 CAPACITY **105Ah @ 20Hr**
 MATERIAL **Polypropylene**
 BATTERY **VRLA AGM / Non-Spillable / Maintenance-Free**
 COLOR **Maroon**
 WATERING **No Watering Required** 
 IEC 61427 **8+ Years Life**



12V

PRODUCT + PHYSICAL SPECIFICATIONS

Model	Terminal Type ^D	Dimensions ^B Inches (mm)			Weight Lbs. ^F (kg)	Handles	Installation Orientation
		Length	Width	Height ^C			
SAGM 12 105	M8/LT	12.80 (325)	6.81 (173)	9.34 (237)	67 (30)	Molded Plastic	Horizontal and Vertical

ELECTRICAL SPECIFICATIONS

Voltage	Capacity ^A Amp-Hours (Ah)					Energy kWh	Internal Resistance (mΩ)	Short Circuit Current (A)
	10-Hr	20-Hr	48-Hr	72-Hr	100-Hr			
12V	94	105	109	111	113	1.26	4.80	2555

CHARGING INSTRUCTIONS

Charger Voltage Settings (at 77°F/25°C)				
System Voltage	12V	24V	36V	48V
Maximum Charge Current (A)	20% of C ₂₀			
Absorption Voltage (2.40 V/cell)	14.40	28.80	43.20	57.60
Float Voltage (2.25 V/cell)	13.50	27.00	40.50	54.00

Do not install or charge batteries in a sealed or non-ventilated compartment. Constant under or overcharging will damage the battery and shorten its life as with any battery.

CHARGING TEMPERATURE COMPENSATION

Add	Subtract
0.005 volt per cell for every 1°C below 25°C 0.0028 volt per cell for every 1°F below 77°F	0.005 volt per cell for every 1°C above 25°C 0.0028 volt per cell for every 1°F above 77°F

STATE OF CHARGE MEASURE OF OPEN-CIRCUIT VOLTAGE

Percentage Charge	Cell	12 Volt
100	2.14	12.84
75	2.09	12.54
50	2.04	12.24
25	1.99	11.94
0	1.94	11.64

OPERATIONAL DATA

Operating Temperature	Self Discharge
-4°F to 122°F (-20°C to 50°C) At temperatures below 32°F (0°C) maintain a state of charge greater than 60%	Less than 3% per month depending on storage temperature conditions



Designed in compliance with applicable BCI, DIN, BS and IEC standards. Tested in compliance to BCI and IEC standards.

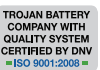
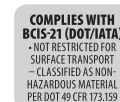

SOLAR CYCLE-LIFE

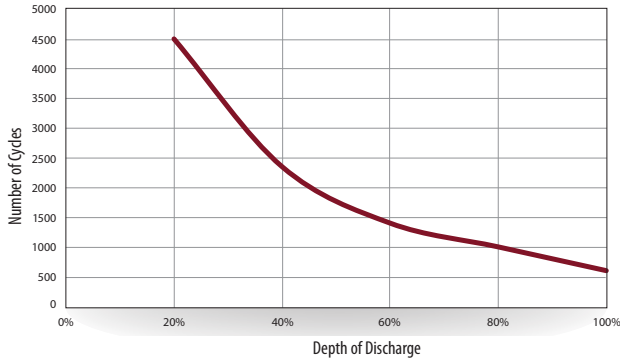

CAPACITY VS. OPERATING TEMPERATURE

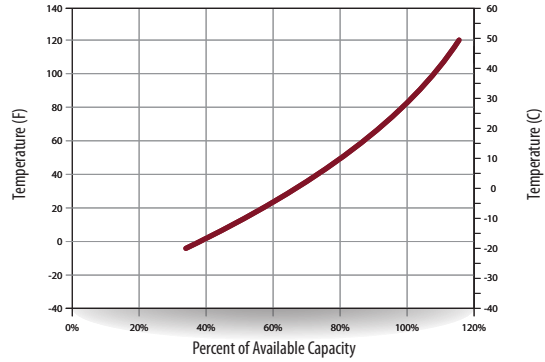

SELF DISCHARGE VS. TIME^E

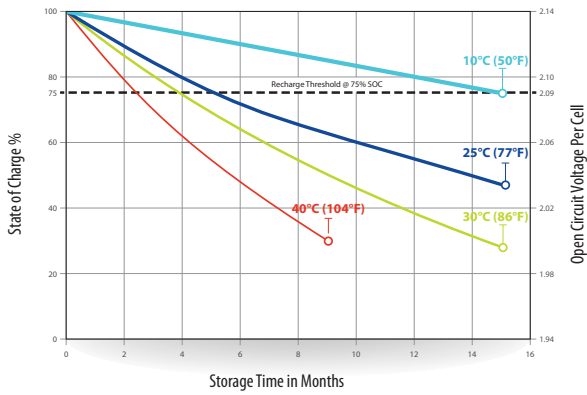

TROJAN SAGM 12 105 PERFORMANCE

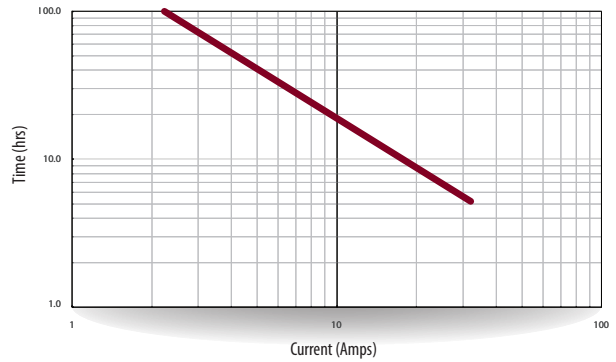

BATTERY DIMENSIONS

Dimensions Inches (mm) - shown with M8, height is 10.19 (259) with LT

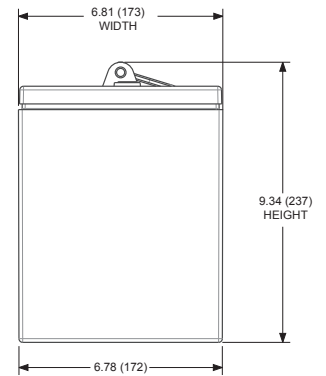
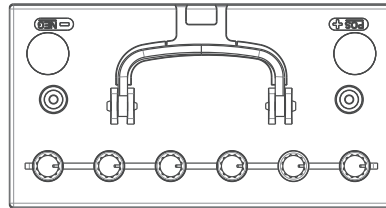
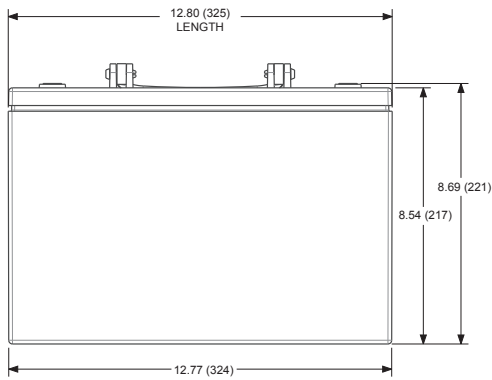

TERMINAL CONFIGURATIONS^D

M8

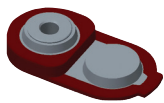

Battery Height with Terminal in Inches (mm)
8.69 (221)

Torque Values: in-lb (Nm)
Bolt: 85 – 90 (10 – 11)

M8 with LT Adapter (adapter provided but not installed)



Battery Height with Terminal in Inches (mm)
10.19 (259)

Torque Values: in-lb (Nm)
Connection to M8: 85 – 90 (10-11)
Connection to LT: 65 – 75 (7.5 – 8.5)

Bolt Size
M8 x 1.25

- A. The amount of amp-hours (Ah) a battery can deliver when discharged at a constant rate at 86°F (30°C) for all rates and maintain a voltage above 1.75 V/cell. Capacities are based on peak performance.
- B. Dimensions may vary depending on type of handle or terminal. Batteries should be mounted with 0.5 inches (12.7 mm) spacing minimum.

- C. Height taken from bottom of the battery to the highest point on the battery. Heights may vary depending on type of terminal.
- D. Terminal images are representative only.
- E. A boost charge should be performed every 6 months when batteries are in storage.
- F. Weight may vary.