

Reguero Baterias.es 91-7973512

12 OPzS 1200

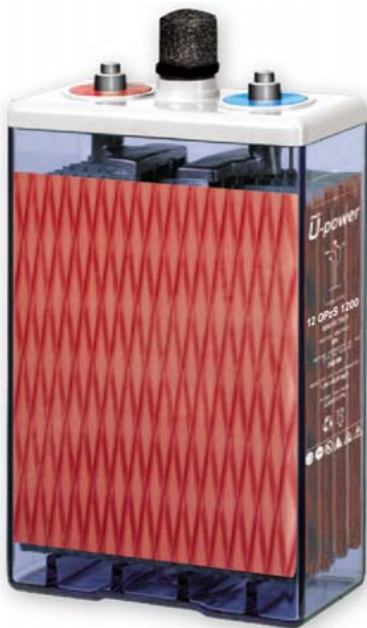

Specification	
Float Charge	U = 2.23 V/cell ± 1%, between 10°C and 30°C $\Delta U/\Delta T = -0.004$ V/K below 10°C in the monthly average
Boost Charge	U = 2.35 to 2.40 V/cell, time limited
Dimension	Length 210 mm
	Width 275 mm
	Height 711 mm
Weight	Dry: 66 kg Wet: 93 kg
Self Discharge	Approx. 2% per month at 20°C
Positive Electrode	Tubular plate with low antimony alloy (< 2 %)
Negative Electrode	Flat with long life expander active material
Separation	Microporous separator
Electrolyte	Sulphuric acid of 1.24 kg/l at 20°C
Container	High impact, transparent SAN
Lid	ABS (SAN)* in grey color
Blocks with Blind Cells	4V, 6V, 8V, 10V
Plugs	Ceramic plugs according to DIN 40740
Pole Sealing	100 % gas-and electrolytetight, sliding-pole
Connector	Flexible insulated copper cable with cross-section of 35, 50, 70, 95 or 120 mm ² (35, 50 or 70 mm ²)*
Kind of Protection	IP 25 regarding DIN 40050, touch protected according VBG 4
Reference Temperature	20°C at C10 (1.80 V/cell) and 25°C at C100 (1.85 V/cell)
Initial Capacity	100%
Depth of Discharge	Normally up to 80%
	More than 80% DOD or discharges beyond final discharge voltages (dependent on discharge current) have to be avoided

Constant Current Discharge (Amperes) at 20°C (68°F)

F.V/Time	15min	30min	1h	2h	3h	4h	5h	6h	8h	10h	20h
1.90V/cell	374.1	363.8	348.8	273.9	222.9	190.2	164.3	147.9	121.5	106.8	64.1
1.87V/cell	500.5	475.3	404.4	313.0	253.9	215.4	187.5	162.3	135.3	116.6	66.5
1.83V/cell	635.2	582.1	477.6	356.3	282.6	237.5	204.2	176.5	146.8	124.5	68.9
1.80V/cell	757.9	659.0	530.6	381.9	301.9	250.5	214.8	185.2	153.1	127.8	70.6
1.75V/cell	900.0	762.6	601.7	412.9	318.0	260.3	220.3	185.9	153.9	130.4	71.7
1.70V/cell	1028.1	856.8	645.2	431.8	325.4	264.4	229.6	193.2	158.5	131.7	72.3

Constant Power Discharge (Watts) at 20°C (68°F)

F.V/Time	15min	30min	1h	2h	3h	4h	5h	6h	8h	10h	20h
1.90V/cell	711.8	694.1	669.1	528.6	432.6	370.0	319.5	288.9	237.0	210.3	127.5
1.87V/cell	944.5	897.3	766.3	597.3	486.7	416.9	364.1	314.8	263.4	227.9	130.4
1.83V/cell	1170.7	1079.8	883.5	668.8	536.1	451.8	390.0	339.0	283.5	240.8	135.0
1.80V/cell	1381.7	1203.3	976.7	711.1	566.6	472.2	406.1	352.1	294.0	245.0	138.3
1.75V/cell	1603.7	1375.7	1095.7	761.9	592.1	487.6	415.0	350.6	293.5	248.1	139.9
1.70V/cell	1784.8	1525.9	1163.9	793.2	600.4	492.5	431.0	364.0	293.5	249.9	137.4

12 OPzS 1200

Dimension

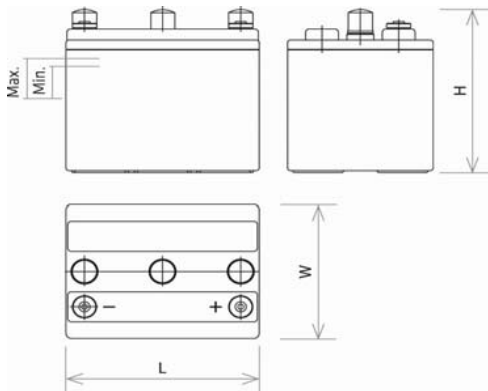

Voltage vs. % of discharge at Cx

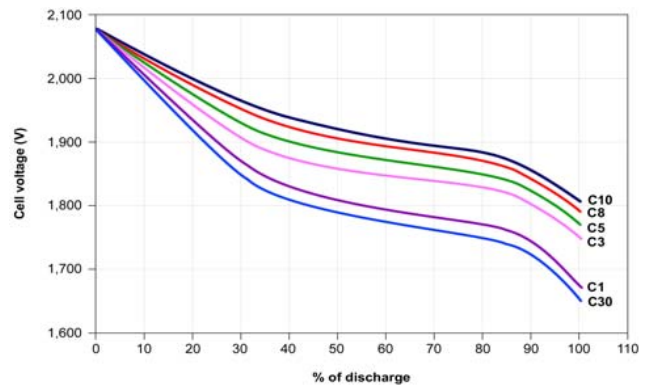

Lifetime in cycles vs. temperature at DOD

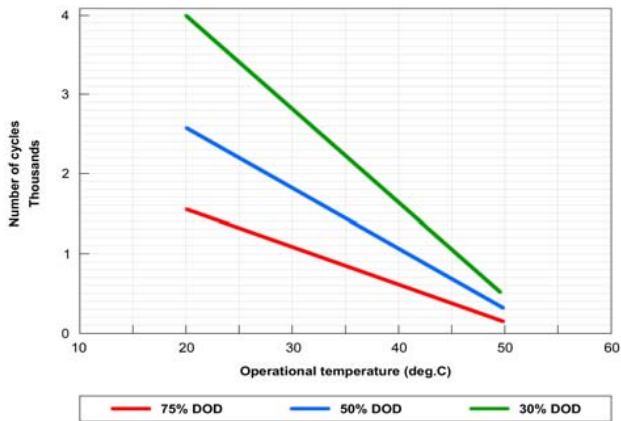

Float voltage as f (T)

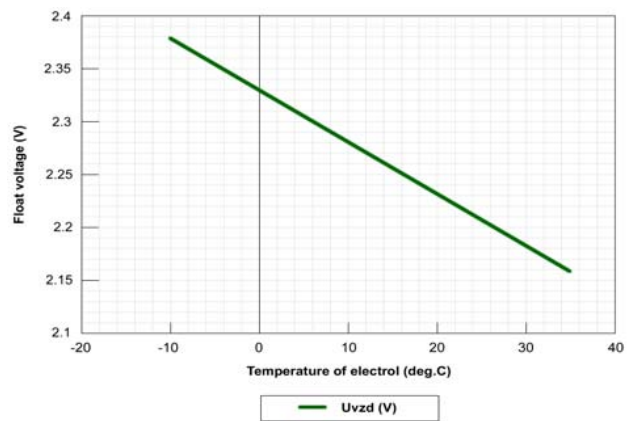

Gassing voltage as f (T)

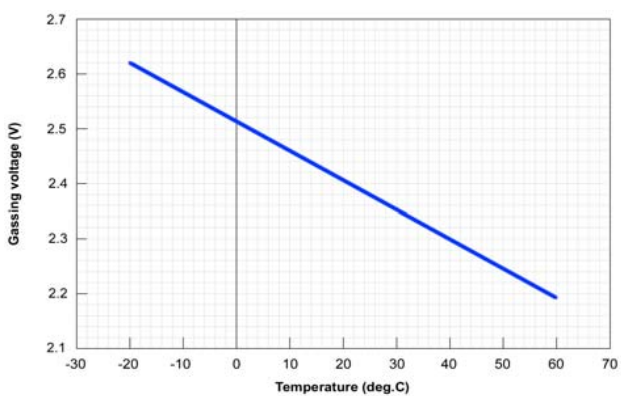

Charging of OPzS cells with IU charger

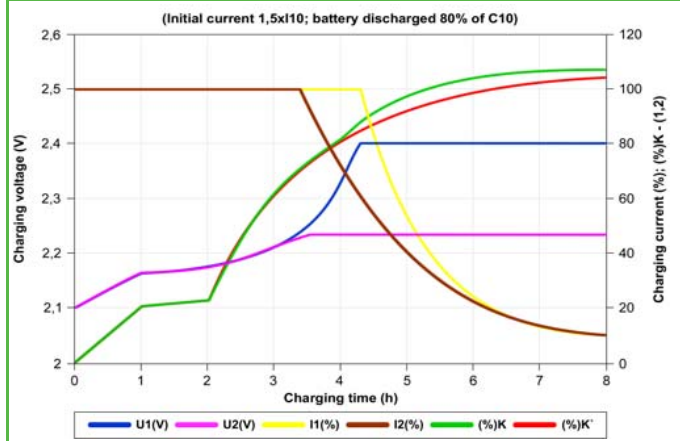

ETL SEMKO

