

Reguero Baterias.es 91-7973512

12 OPzS 1500

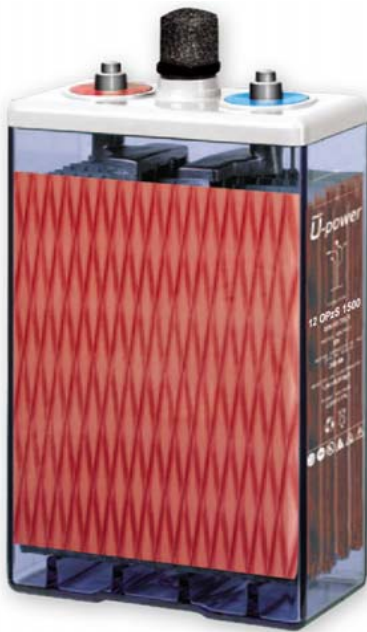

Specification	
Float Charge	U = 2.23 V/cell ± 1%, between 10°C and 30°C $\Delta U/\Delta T = -0.004$ V/K below 10°C in the monthly average
Boost Charge	U = 2.35 to 2.40 V/cell, time limited
Dimension	Length 210 mm
	Width 275 mm
	Height 861 mm
Weight	Dry: 88 kg Wet: 119 kg
Self Discharge	Approx. 2% per month at 20°C
Positive Electrode	Tubular plate with low antimony alloy (< 2 %)
Negative Electrode	Flat with long life expander active material
Separation	Microporous separator
Electrolyte	Sulphuric acid of 1.24 kg/l at 20°C
Container	High impact, transparent SAN
Lid	ABS (SAN)* in grey color
Blocks with Blind Cells	4V, 6V, 8V, 10V
Plugs	Ceramic plugs according to DIN 40740
Pole Sealing	100 % gas-and electrolytetight, sliding-pole
Connector	Flexible insulated copper cable with cross-section of 35, 50, 70, 95 or 120 mm ² (35, 50 or 70 mm ²)*
Kind of Protection	IP 25 regarding DIN 40050, touch protected according VBG 4
Reference Temperature	20°C at C10 (1.80 V/cell) and 25°C at C100 (1.85 V/cell)
Initial Capacity	100%
Depth of Discharge	Normally up to 80%
	More than 80% DOD or discharges beyond final discharge voltages (dependent on discharge current) have to be avoided

Constant Current Discharge (Amperes) at 20°C (68°F)

F.V/Time	15min	30min	1h	2h	3h	4h	5h	6h	8h	10h	20h
1.90V/cell	402.0	393.5	367.6	318.2	261.7	228.8	199.2	178.5	146.9	126.7	804
1.87V/cell	512.5	494.0	461.8	365.2	299.1	257.9	226.4	199.9	167.0	142.3	81.8
1.83V/cell	662.5	626.7	551.8	427.2	343.5	289.4	252.8	220.5	183.2	154.6	86.1
1.80V/cell	790.5	743.2	617.1	466.6	370.4	309.7	268.9	233.3	192.1	161.3	91.0
1.75V/cell	949.0	863.1	701.0	511.5	398.7	329.3	283.7	240.6	198.4	165.9	93.0
1.70V/cell	1161.2	1007.7	770.0	541.4	414.7	337.9	292.4	250.0	204.4	167.2	93.9

Constant Power Discharge (Watts) at 20°C (68°F)

F.V/Time	15min	30min	1h	2h	3h	4h	5h	6h	8h	10h	20h
1.90V/cell	765.0	750.8	705.0	614.2	508.0	445.1	387.3	348.7	286.5	249.6	160.1
1.87V/cell	967.1	932.7	875.1	696.8	573.3	499.0	439.7	387.8	325.2	278.2	160.2
1.83V/cell	1221.0	1162.5	1020.9	801.9	651.7	550.4	482.9	423.4	353.7	299.0	168.8
1.80V/cell	1441.1	1357.1	1136.1	868.8	695.2	583.7	508.5	443.4	369.0	309.3	178.3
1.75V/cell	1691.2	1557.1	1276.5	943.6	742.3	616.7	534.4	453.8	378.6	315.7	181.6
1.70V/cell	2015.8	1794.7	1389.1	994.6	765.1	629.6	548.7	470.9	204.4	317.2	178.6

12 OPzS 1500

Dimension

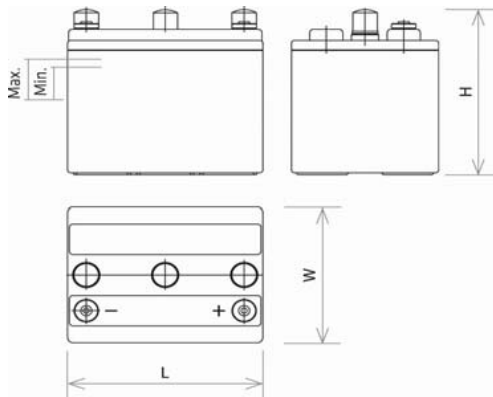

Voltage vs. % of discharge at Cx

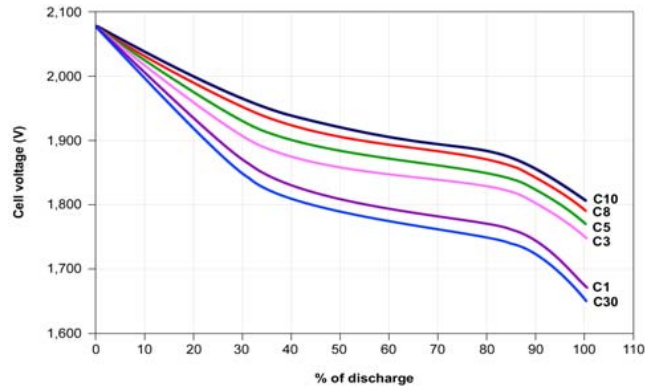

Lifetime in cycles vs. temperature at DOD

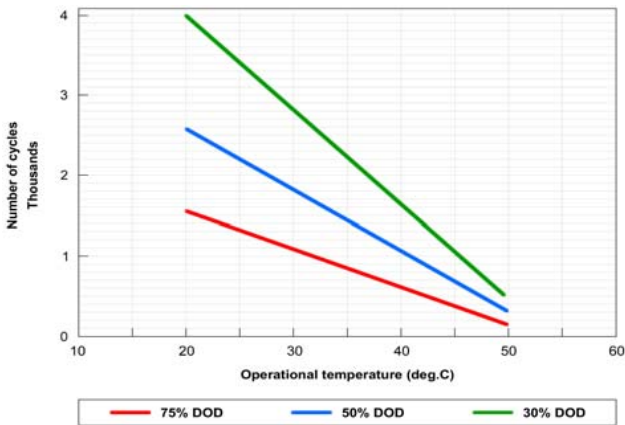

Float voltage as f (T)

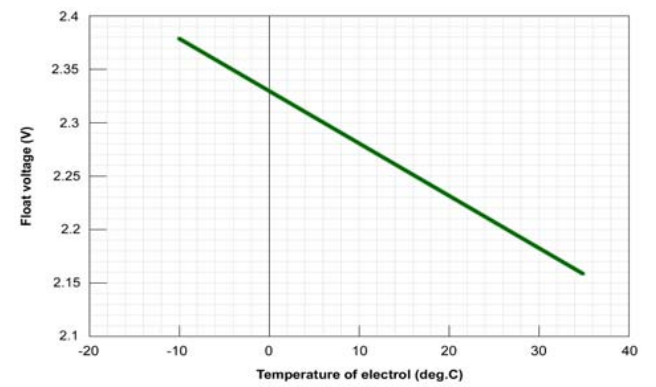

Gassing voltage as f (T)

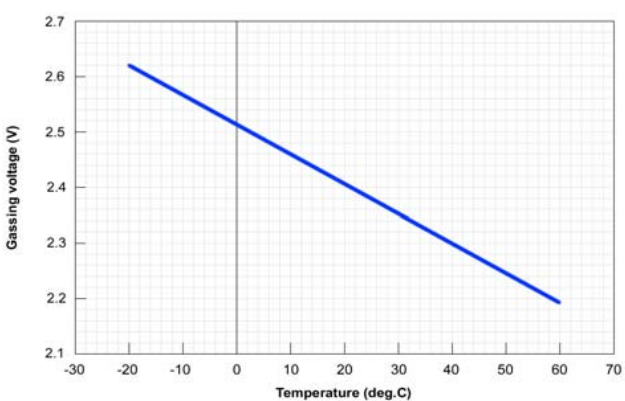

Charging of OPzS cells with IU charger

