

7 OPzS 490 Reguero Baterias.es 91-7973512

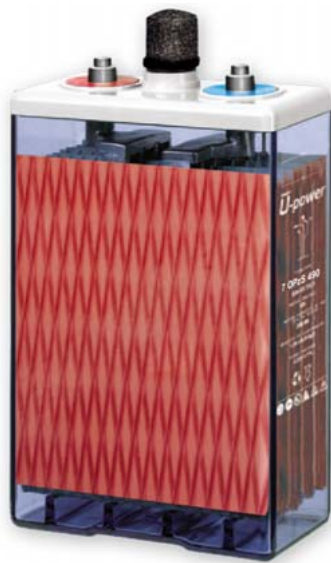

Specification	
Float Charge	U = 2.23 V/cell ± 1%, between 10°C and 30°C $\Delta U/\Delta T = -0.004$ V/K below 10°C in the monthly average
Boost Charge	U = 2.35 to 2.40 V/cell, time limited
Dimension	Length 166 mm Width 206 mm Height 536 mm
Weight	Dry: 28 kg Wet: 39 kg
Self Discharge	Approx. 2% per month at 20°C
Positive Electrode	Tubular plate with low antimony alloy (< 2 %)
Negative Electrode	Flat with long life expander active material
Separation	Microporous separator
Electrolyte	Sulphuric acid of 1.24 kg/l at 20°C
Container	High impact, transparent SAN
Lid	ABS (SAN)* in grey color
Blocks with Blind Cells	4V, 6V, 8V, 10V
Plugs	Ceramic plugs according to DIN 40740
Pole Sealing	100 % gas-and electrolytetight, sliding-pole
Connector	Flexible insulated copper cable with cross-section of 35, 50, 70, 95 or 120 mm ² (35, 50 or 70 mm ²)*
Kind of Protection	IP 25 regarding DIN 40050, touch protected according VBG 4
Reference Temperature	20°C at C10 (1.80 V/cell) and 25°C at C100 (1.85 V/cell)
Initial Capacity	100%
Depth of Discharge	Normally up to 80% More than 80% DOD or discharges beyond final discharge voltages (dependent on discharge current) have to be avoided

Constant Current Discharge (Amperes) at 20°C (68°F)

F.V/Time	15min	30min	1h	2h	3h	4h	5h	6h	8h	10h	20h
1.90V/cell	182.1	176.6	158.6	116.3	93.8	78.2	68.9	61.7	51.3	45.5	27.1
1.87V/cell	244.1	222.9	180.5	134.1	107.1	88.5	77.7	67.9	56.5	48.3	27.4
1.83V/cell	304.2	266.4	220.5	150.6	118.8	98.2	85.5	73.7	61.3	51.7	29.1
1.80V/cell	346.1	298.1	230.2	160.6	126.1	103.3	89.6	77.7	63.5	53.2	29.6
1.75V/cell	410.3	337.6	252.9	171.9	130.8	106.5	91.9	78.5	64.3	54.0	29.6
1.70V/cell	464.5	371.3	267.0	174.1	132.6	107.7	94.2	81.3	66.3	53.7	29.7

Constant Power Discharge (Watts) at 20°C (68°F)

F.V/Time	15min	30min	1h	2h	3h	4h	5h	6h	8h	10h	20h
1.90V/cell	346.4	336.9	304.2	224.4	182.1	152.0	133.9	120.4	100.0	89.6	53.9
1.87V/cell	460.7	420.8	342.0	255.8	205.3	171.2	150.9	131.7	109.9	94.4	53.8
1.83V/cell	560.7	494.1	408.0	282.7	225.3	186.8	163.4	141.5	118.4	100.0	57.1
1.80V/cell	630.9	544.3	423.9	299.1	236.8	194.8	169.5	147.7	122.0	101.9	58.1
1.75V/cell	731.1	609.0	460.5	317.2	243.6	199.5	173.1	148.1	122.7	102.7	57.8
1.70V/cell	806.4	661.4	481.7	319.9	244.6	200.6	176.9	153.2	66.3	101.9	56.5

7 OPzS 490

Dimension

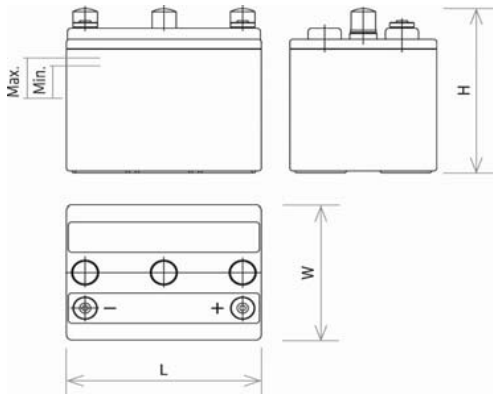

Voltage vs. % of discharge at Cx

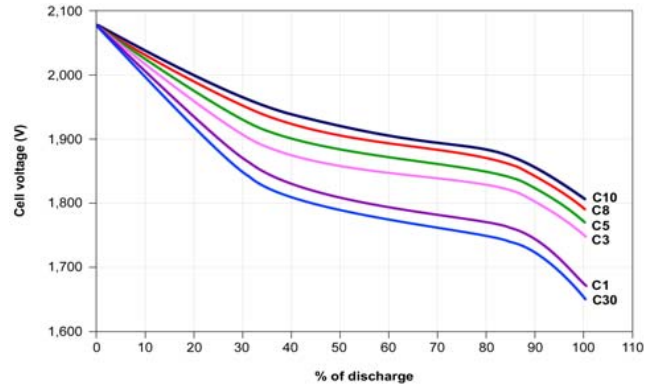

Lifetime in cycles vs. temperature at DOD

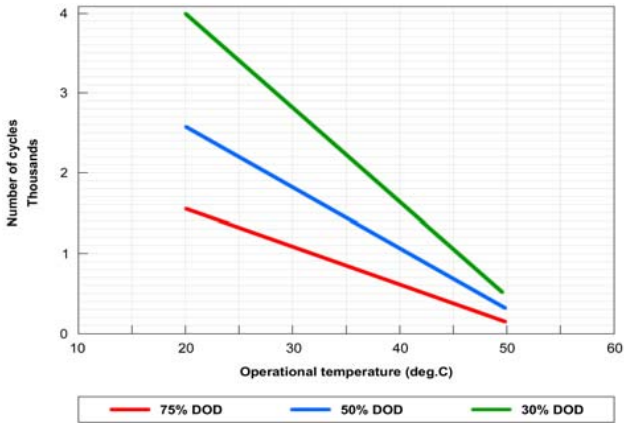

Float voltage as f (T)

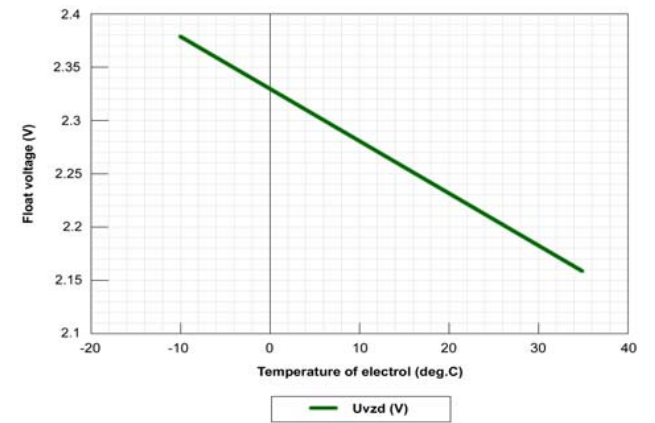

Gassing voltage as f (T)

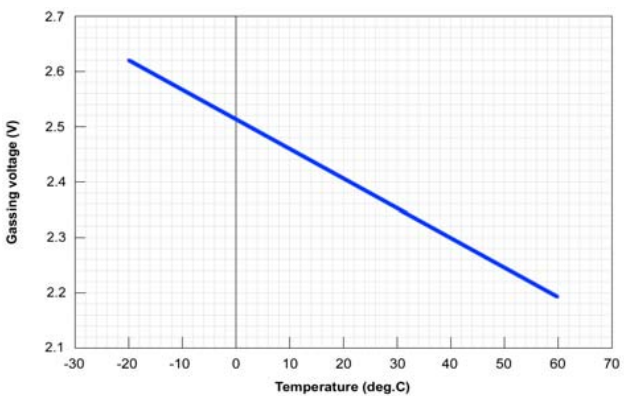

Charging of OPzS cells with IU charger

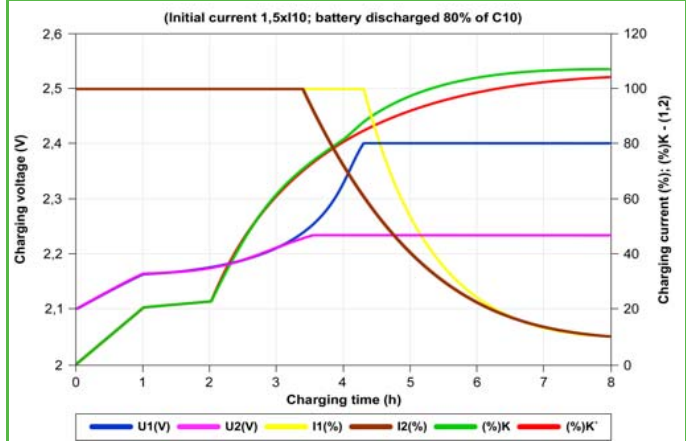

MH26866



ETL SEMKO

